

# Romotop® TEON P 30

PLECH  
STAHL KOMPLETT  
FULL STEEL

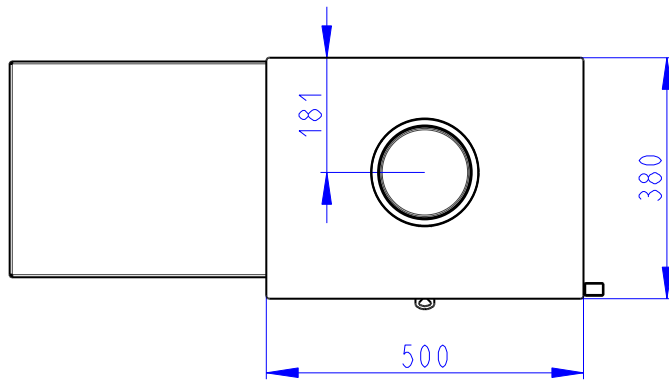

SEKUNDARNI VZDUCH  
Sekundärluft  
Secondary air  
A/UND/AND  
PRIMARNI VZDUCH  
Primärluft  
Primary air

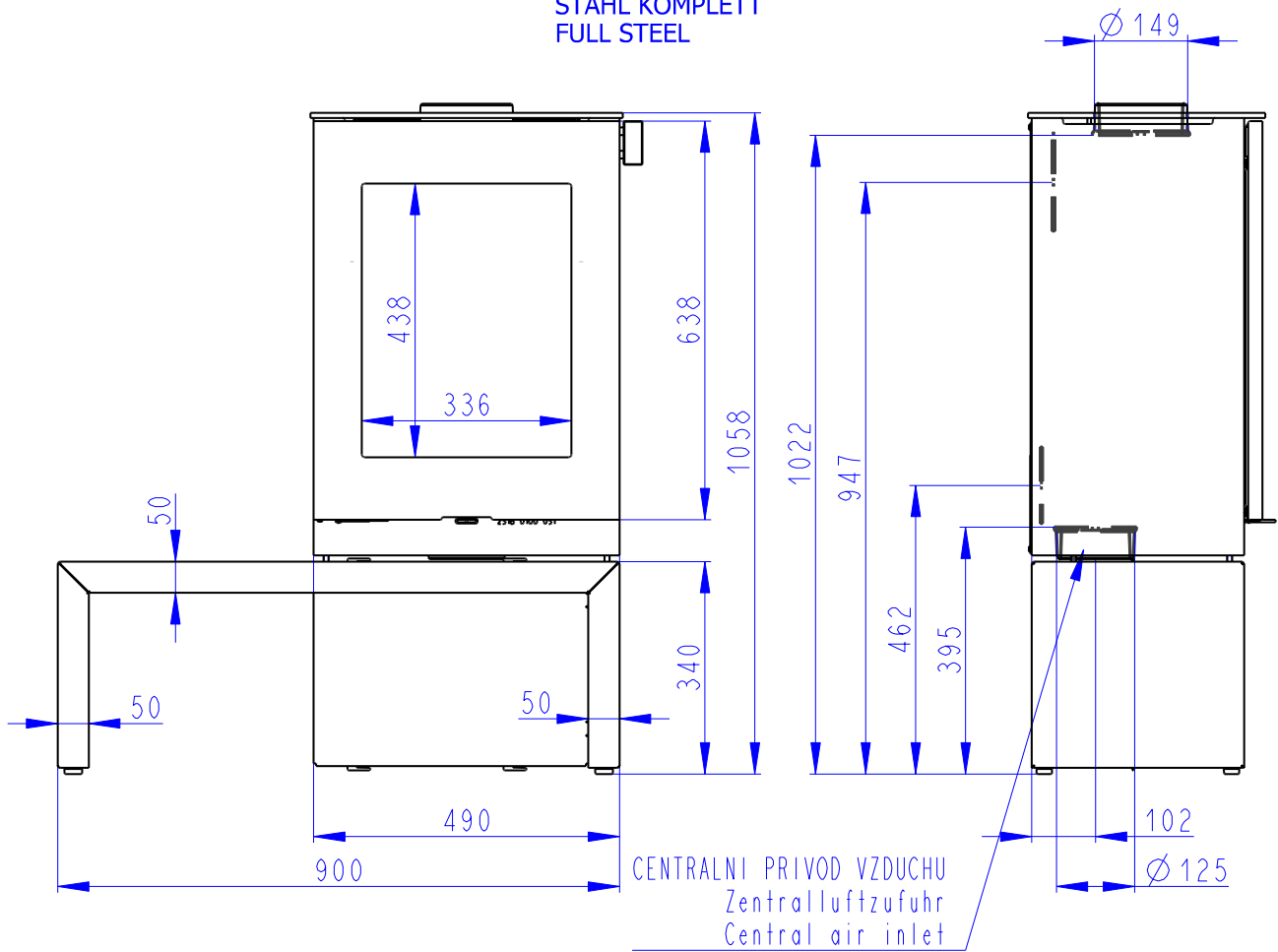
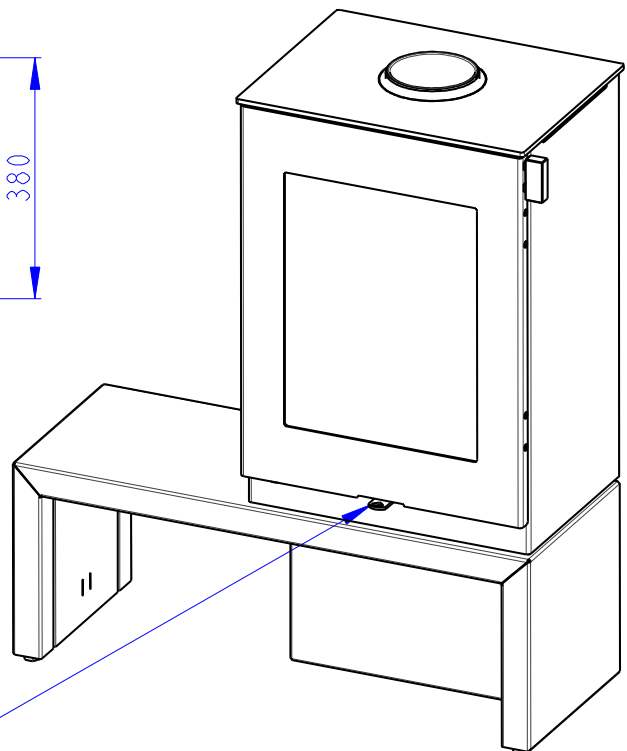

**Declared qualities stated**

 Harmonised technical specification ✓ EN 16510-1 ed.2:2023 | EN 16510-2-1:2022 ✓ Ecodesign ✓ DIN+ ✓ BImSchV2 ✓ 15a B-VG 2015

Classification of appliance	Type BE			
		Nominal heat output (nom)	Part load heat output (part)	
Energy efficiency	$\eta_{nom}   \eta_{part}$	81	---	%
Seasonal space heating energy efficiency at nominal heat output	$\eta_{snom}   \eta_{s part}$	71	---	%
Energy Efficiency Index	EEI	107		
Energy label		A+		
Fuel		Wood logs		
Fuel length		200-330		mm
Average fuel consumption		1,69	---	kg/h
Allowed fuel dose		2,3		kg/h
Fuel supply interval		1 hour		
Amount of combustion air		21,4		m <sup>3</sup> /h
Nominal heat output	$P_{nom}   P_{part}$	5,8	---	kW
Hot-water exchanger nominal heat output	$P_{Wnom}   P_{W part}$	---	---	kW
Maximum water operating pressure	$P_W$	---		bar
Dry flue gas mass flow rate	$\Phi_{f, g nom}   \Phi_{f, g part}$	6,9	---	g/s
Flue gas outlet temperature	$T_{snom}   T_{s part}$	313	---	°C
Flue draught	$P_{nom}   P_{part}$	12	---	Pa
Chimney temperature class		T400		
Connection to the common chimney		Yes		
Storage of fuel in the wood shed area		Yes		
Maximum warming of the wood in the wood shed		20		°C
Dust O <sub>2</sub> = 13 %	$PM_{nom}   PM_{part}$	26	---	mg/Nm <sup>3</sup>
CO <sub>2</sub>		10,24	---	%
Emissions of gases of combustion (CO in the flue gases at O <sub>2</sub> = 13 %)	$CO_{nom}   CO_{part}$	0,0689 862	---	% mg/Nm <sup>3</sup>
OGC O <sub>2</sub> = 13 %	$OGC_{nom}   OGC_{part}$	50	---	mg/Nm <sup>3</sup>
NOx O <sub>2</sub> = 13 %	$NO_{xnom}   NO_{x part}$	114	---	mg/Nm <sup>3</sup>
Automatic regulation unit of burning		---	---	
Electricity consumption in standby mode	$e_{ sb}$	---		kW
Electricity consumption	$e_{ max}   e_{ min}$	---	---	kW
Standing air loss	$V_h$	---		m <sup>3</sup> /h
Intermittent operation   Continuous operation	INT   CON	INT		

**Basic technical data**

Principal dimensions (Height   Width   Length)	H   W   L	1058   900   380	mm
Combustion chamber dimensions	H   W   L	357   344   276	mm
Fireplace door dimensions	H   W   L	---   ---   ---	mm
Axis height of the rear (side) outlet		947	mm
Volume of hot-water exchanger		---	l
Flue diameter		150	mm
Diameter of flue throat	$d_{out}$	150	mm
Diameter of external air connection		125	mm
Maximum length (pipe) of external air intake		5000	mm
Weight	m	131	kg
Load bearing capacity	$m_{chim}$	200	kg

**Heat capacity**

minimum size of the room of appliance installation

Insulation of the house – very good (20 W/m <sup>3</sup> )	e.g. new, insulated house / permanently inhabited	216	m <sup>3</sup>
Insulation of the house – good (22,5 W/m <sup>3</sup> )		192	m <sup>3</sup>
Insulation of the house – middle (32 W/m <sup>3</sup> )		135	m <sup>3</sup>
Insulation of the house – bad (45 W/m <sup>3</sup> )		96	m <sup>3</sup>
Insulation of the house – very bad (50 W/m <sup>3</sup> )	e.g. old, uninsulated house / cottage / chalet	86	m <sup>3</sup>

**Distances from flammable materials**

with un-insulated flue pipe (provided on the product label)

**Note**

Back	$d_R$	200	mm
Front	$d_P$	1300	mm
Front to the floor	$d_F$	0	mm
Side	$d_S$	250	mm
Side with glass	$d_{S1}$	---	mm
Side – niche	$d_{S2}$	200	mm
Side – location 45°	$d_{S3}$	---	mm
Side radiation	$d_L$	0	mm
From the floor	$d_B$	0	mm
From the ceiling	$d_C$	800	mm

**Distances from flammable materials with insulated flue pipe \***

Back	$d_R$	---	mm
Side	$d_S$	---	mm

**Distances from flammable materials with hanging plate (shielding)**

Back	$d_R$	---	mm
Side	$d_S$	---	mm

**Distances from flammable materials with insulated flue pipe and hanging plate (shielding) \***

Back	$d_R$	---	mm
Side	$d_S$	---	mm

**Distances from nonflammable materials**

Back	$d_{Rnon}$	80	mm
Side	$d_{Snon}$	150	mm
Side – niche	$d_{S2non}$	80	mm
Side – location 45°	$d_{S3non}$	---	mm

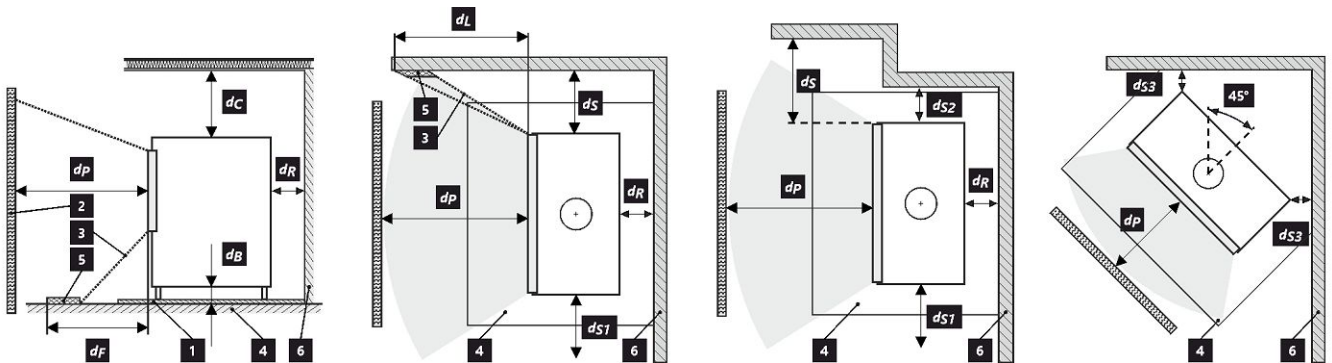

1 floor | 2 object | 3 radiation area | 4 floor protection plate | 5 critical area (due to radiation) | 6 flammable wall

All local regulations, including regulations relating to national and European standards, must be observed during the installation and operation of the product.

A product installed on a floor made of flammable materials must be fitted with a floor protective plate made of nonflammable material extending beyond its footprint by at least 400 mm in the front direction and 100 mm in other directions. The product must be installed on floors with adequate load-bearing capacity.

\* The distance assumes the use of an insulated flue pipe with a minimum insulation thickness of 25 mm up to the product.

**Distance from flammable (nonflammable) materials – rear flue connection**

Back	$d_R$	200	mm
Side	$d_S$	250	mm

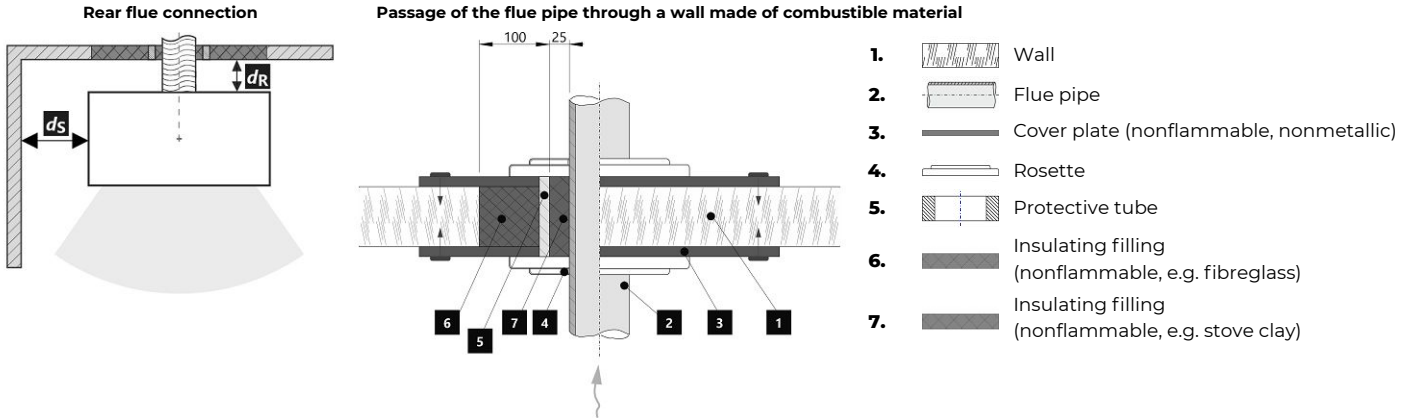

**Distance from flammable (nonflammable) materials – rear flue connection (insulated)**

Back	$d_R$	---	mm
Side	$d_S$	---	mm

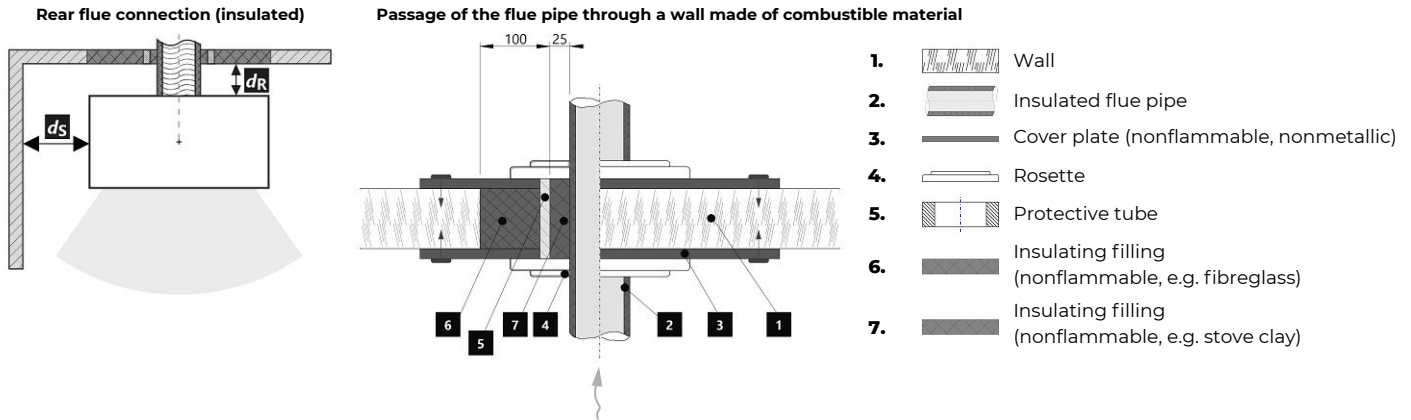

**Deklarierte Produkteigenschaften**

Harmonisierte technische Spezifikation ✓ EN 16510-1 ed.2:2023 | EN 16510-2-1:2022 ✓ Ecodesign ✓ DIN+ ✓ BImSchV2 ✓ 15a B-VG 2015

Produktklassifizierung	Type BE			
		Nennwärmeleistung (nom)	Teillastwärmeleistung (part)	
Energiewirkungsgrad	$\eta_{nom}   \eta_{part}$	81	---	%
Raumheizungs-Jahresnutzungsgrad	$\eta_{Snom}   \eta_{Spart}$	71	---	%
Energieeffizienzindex	EEI	107		
Energielabel		A+		
Brennstoff		Scheitholz		
Brennstofflänge		200-330		mm
Durchschnittlicher Brennstoffverbrauch		1,69	---	kg/h
Zulässiger Brennstoffverbrauch		2,3		kg/h
Brennstofflieferintervall		1 Stunde		
Verbrennungsluftmenge		21,4		m <sup>3</sup> /h
Nennwärmeleistung	$P_{nom}   P_{part}$	5,8	---	kW
Wärmetauscherleistung	$P_{Wnom}   P_{Wpart}$	---	---	kW
Maximaler Wasserbetriebsdruck	$p_W$	---		bar
Rauchgasmassenstrom (trocken)	$\Phi_{f,g nom}   \Phi_{f,g part}$	6,9	---	g/s
Rauchgasaustrittstemperatur	$T_{snom}   T_{spart}$	313	---	°C
Förderdruck	$p_{nom}   p_{part}$	12	---	Pa
Temperaturklasse		T400		
Mehrfachbelegung		Ja		
Lagerung von Brennstoff im Holzfach		Ja		
Maximale Erwärmung des Holzes im Holzfach		20		°C
Feinstaub O <sub>2</sub> = 13 %	$PM_{nom}   PM_{part}$	26	---	mg/Nm <sup>3</sup>
CO <sub>2</sub>		10,24	---	%
Abgasemission (CO in den Abgasen bei O <sub>2</sub> = 13 %)	$CO_{nom}   CO_{part}$	0,0689 862	---	% mg/Nm <sup>3</sup>
OGC O <sub>2</sub> = 13 %	$OGC_{nom}   OGC_{part}$	50	---	mg/Nm <sup>3</sup>
NO <sub>x</sub> O <sub>2</sub> = 13 %	$NO_{xnom}   NO_{xpart}$	114	---	mg/Nm <sup>3</sup>
Automatische Abbrandsteuerung		---	---	
Stromverbrauch im Bereitschaftszustand	$e_{lSB}$	---		kW
Stromverbrauch	$e_{lmax}   e_{lmin}$	---	---	kW
Ständiger Luftverlust	$V_h$	---		m <sup>3</sup> /h
Intervallbetrieb   Dauerbetrieb	INT   CON	INT		

**Technische Grunddaten**

Hauptabmessungen (Höhe   Breite   Tiefe)	H   W   L	1058   900   380	mm
Abmessungen der Brennkammer (Höhe   Breite   Tiefe)	H   W   L	357   344   276	mm
Abmessungen der Feuerraumtür (Höhe   Breite   Tiefe)	H   W   L	---   ---   ---	mm
Achshöhe hinterer (seitlichen) Rauchrohanschluss		947	mm
Volumen Wärmetauscher		---	l
Rauchrohrdurchmesser		150	mm
Abgasstutzen	$d_{out}$	150	mm
Durchmesser zentrale Luftzufuhr		125	mm
Maximale Länge (Rohrleitung) der zentralen Luftzufuhr		5000	mm
Gewicht	m	131	kg
Tragfähigkeit	$m_{chim}$	200	kg

## Heizleistung (Brennwert)

mindestraumgröße für die Installation des Produkts

Wärmedämmung des Hauses – sehr gut (20 W/m <sup>3</sup> )	z.B. neues, isoliertes Haus / ständig bewohnt	216	m <sup>3</sup>
Wärmedämmung des Hauses – gut (22,5 W/m <sup>3</sup> )		192	m <sup>3</sup>
Wärmedämmung des Hauses – mittel (32 W/m <sup>3</sup> )		135	m <sup>3</sup>
Wärmedämmung des Hauses – schlecht (45 W/m <sup>3</sup> )		96	m <sup>3</sup>
Wärmedämmung des Hauses – sehr schlecht (50 W/m <sup>3</sup> )	z.B. altes, ungedämmtes Haus / Hütte / Chalet	86	m <sup>3</sup>

## Abstand zu brennbaren Materialien

mit unisoliertem Rauchrohr (auf dem Typenschild angegeben)

Bemerkung

Rückwand	$d_R$	200	mm
Strahlungsbereich	$d_P$	1300	mm
Strahlungsbereich zum Boden	$d_F$	0	mm
Seitenwände	$d_S$	250	mm
Seite mit Glas	$d_{S1}$	---	mm
Seite – Nische	$d_{S2}$	200	mm
Seite – Ausrichtung 45°	$d_{S3}$	---	mm
Seitliche Strahlung	$d_L$	0	mm
Von dem Boden	$d_B$	0	mm
Von der Decke	$d_C$	800	mm

## Abstand zu brennbaren Materialien mit isoliertem Rauchrohr \*

Rückwand	$d_R$	---	mm
Seitenwände	$d_S$	---	mm

## Abstand zu brennbaren Materialien mit Aufhängeblech (Abschirmung)

Rückwand	$d_R$	---	mm
Seitenwände	$d_S$	---	mm

## Abstand zu brennbaren Materialien mit isoliertem Rauchrohr und Aufhängeblech (Abschirmung) \*

Rückwand	$d_R$	---	mm
Seitenwände	$d_S$	---	mm

## Abstand zu nicht brennbaren Materialien

Rückwand	$d_{R_{non}}$	80	mm
Seitenwände	$d_{S_{non}}$	150	mm
Seite – Nische	$d_{S2_{non}}$	80	mm
Seite – Ausrichtung 45°	$d_{S3_{non}}$	---	mm

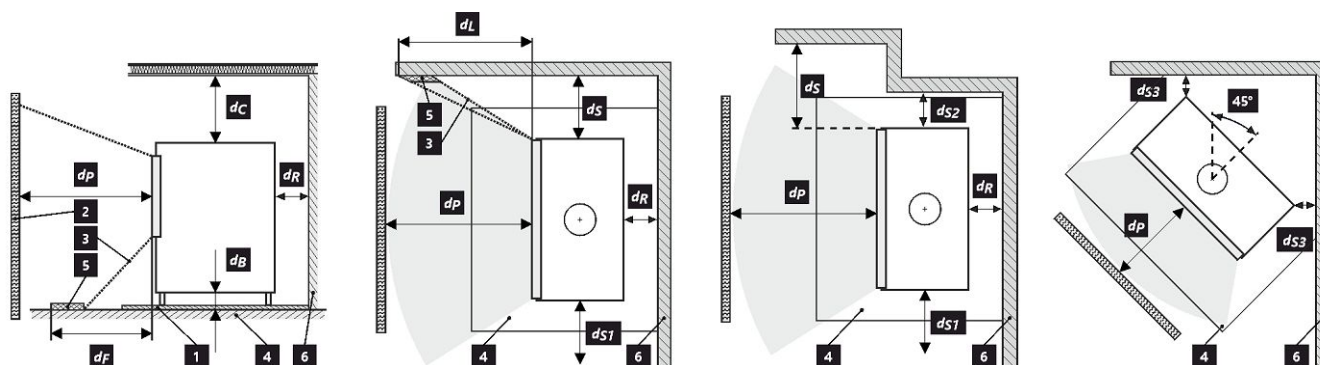

1 Boden | 2 Gegenstand | 3 Strahlungsbereich | 4 Bodenschutzplatte | 5 kritischer Bereich (aufgrund von Strahlung) | 6 Brennbare Wand

Bei der Installation und dem Betrieb des Ofens sind alle örtlichen Vorschriften sowie nationale und europäische Normen zu beachten.

Produkt, das auf einem Boden aus brennbaren Materialien installiert wird, muss mit einer Bodenschutzplatte aus nicht brennbarem Material ausgestattet sein, die mindestens 400 mm in Frontrichtung und 100 mm in anderen Richtungen über die Grundfläche hinausragt. Das Produkt muss auf einem Boden mit ausreichender Tragfähigkeit installiert werden.

\* Der Abstand setzt die Verwendung eines isolierten Rauchrohrs mit einer Mindestdämmstärke von 25 mm bis zum Produkt voraus.

**Abstand zu brennbaren (nicht brennbaren) Materialien – hinterer Rauchrohranschluss**

Rückwand	$d_R$	200	mm
Seitenwände	$d_S$	250	mm

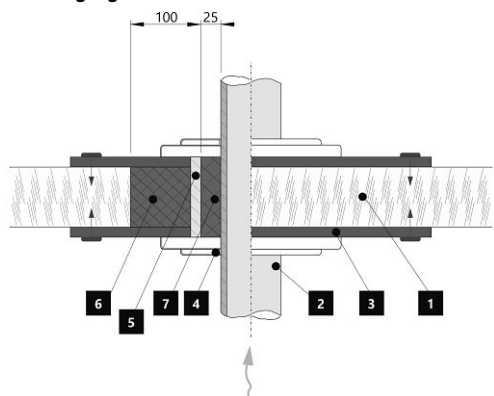
**Durchgang des Rauchrohrs durch eine Wand aus brennbarem Material**

1. Wand
2. Rauchrohr
3. Abdeckplatte (nicht brennbar, kein metallisch)
4. Rosette
5. Schutzrohr
6. Isolierung (nicht entflammbar, z. B. Glasfaser)
7. Isolierung (nicht brennbar, z. B. Ofenlehm)

**Abstand zu brennbaren (nicht brennbaren) Materialien – hinterer Rauchrohranschluss (isoliert)**

Rückwand	$d_R$	---	mm
Seitenwände	$d_S$	---	mm

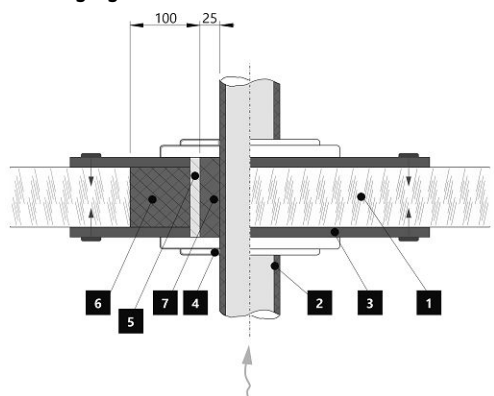
**Durchgang des Rauchrohrs durch eine Wand aus brennbarem Material**

1. Wand
2. Isoliertes Rauchrohr
3. Abdeckplatte (nicht brennbar, kein metallisch)
4. Rosette
5. Schutzrohr
6. Isolierung (nicht entflammbar, z. B. Glasfaser)
7. Isolierung (nicht brennbar, z. B. Ofenlehm)

**Caractéristiques déclarées du produit**

Norme(s) Européennes				✓ EN 16510-1 ed.2:2023   EN 16510-2-1:2022				✓ Ecodesign				✓ DIN+				✓ BImSchV2				✓ 15a B-VG 2015									
Classification de l'appareil										Type BE																			
										Puissance thermique nominale (nom)					Puissance thermique partielle (part)														
Efficacité énergétique										$\eta_{nom}$   $\eta_{part}$					81					---					%				
Efficacité énergétique saisonnier à la puissance thermique nominale de l'appareil										$\eta_{snom}$   $\eta_{spart}$					71					---					%				
Indice d'efficacité énergétique EEI										EEI					107														
Label énergétique															A+														
Combustible															Bûches														
Longueur recommandée de bûches															200-330					mm									
Consommation moyenne de combustible															1,69					---					kg/h				
Charge en bois autorisé															2,3					kg/h									
Intervalle entre les chargements de combustible															1 heure														
Débit massique des fumées															21,4					m <sup>3</sup> /h									
Puissance thermique nominale										$P_{nom}$   $P_{part}$					5,8					---					kW				
Puissance thermique nominale de l'échangeur										$P_{Wnom}$   $P_{Wpart}$					---					---					kW				
Pression d'eau maximale										$P_W$					---					bar									
Débit massique des gaz de combustion secs										$\Phi_{f,g nom}$   $\Phi_{f,g part}$					6,9					---					g/s				
Température de sortie des gaz de combustion										$T_{snom}$   $T_{spart}$					313					---					°C				
Tirage de conduit de fumée										$P_{nom}$   $P_{part}$					12					---					Pa				
Classe de température															T400														
Raccordement à une cheminée collective															Oui														
Stockage du combustible dans range bûches															Oui														
Réchauffement maximal du bois dans range bûches															20					°C									
Poussière O <sub>2</sub> = 13 %										$PM_{nom}$   $PM_{part}$					26					---					mg/Nm <sup>3</sup>				
CO <sub>2</sub>															10,24					---					%				
Résidus de combustion émis (CO dans les résidus de combustion pour O <sub>2</sub> = 13 %)										$CO_{nom}$   $CO_{part}$					0,0689 862					---					%				
OGC O <sub>2</sub> = 13 %										$OGC_{nom}$   $OGC_{part}$					50					---					mg/Nm <sup>3</sup>				
NOx O <sub>2</sub> = 13 %										$NO_{xnom}$   $NO_{xpart}$					114					---					mg/Nm <sup>3</sup>				
Régulation automatique de la combustion															---					---									
Consommation d'énergie en mode veille										$e_{lsB}$					---					---					kW				
Consommation d'électricité										$e_{lmax}$   $e_{lmin}$					---					---					kW				
Standing air loss										$V_h$					---					---					m <sup>3</sup> /h				
Fonctionnement par intermittence   Service ininterrompu										INT   CON					INT														

**Données techniques de base**

Dimensions principales (Hauteur   Largeur   Profondeur)										H   W   L					1058   900   380					mm				
Dimensions de la chambre de combustion (Hauteur   Largeur   Profondeur)										H   W   L					357   344   276					mm				
Dimensions de la porte (Hauteur   Largeur   Profondeur)										H   W   L					---   ---   ---					mm				
Hauteur de l'axe de la sortie arrière (latérale)															947					mm				
Volume de l'échangeur de chaleur															---					l				
Diamètre du conduit de fumée															150					mm				
Diamètre de buse d'air de combustion										$d_{out}$					150					mm				
Diamètre de l'arrivée d'air centrale															125					mm				
Longueur maximale (tuyau) d'arrivée d'air centrale															5000					mm				
Poids										m					131					kg				
Capacité de charge										$m_{chim}$					200					kg				

## Capacité thermique (Pouvoir calorifique)

taille minimale de la pièce où est installé l'appareil

Isolation de la maison – très bon (20 W/m <sup>3</sup> )	par exemple, maison neuve et isolée / habitée en permanence	216	m <sup>3</sup>
Isolation de la maison – bon (22,5 W/m <sup>3</sup> )		192	m <sup>3</sup>
Isolation de la maison – moyen (32 W/m <sup>3</sup> )		135	m <sup>3</sup>
Isolation de la maison – mauvais (45 W/m <sup>3</sup> )		96	m <sup>3</sup>
Isolation de la maison – très mauvais (50 W/m <sup>3</sup> )	par exemple une vieille maison / chalet / chalet non isolé	86	m <sup>3</sup>

## Distance par rapport aux matériaux combustibles

pour un conduit de fum. non isolé (conform. aux la plaque signalétique)

Note

Arrière	$d_R$	200	mm
Avant	$d_p$	1300	mm
Avant (par rapport au sol)	$d_F$	0	mm
Latéral	$d_s$	250	mm
Latéral avec vitre	$d_{s1}$	---	mm
Latéral – niche	$d_{s2}$	200	mm
Latéral – emplacement 45°	$d_{s3}$	---	mm
Rayonnement latéral	$d_L$	0	mm
Depuis le sol	$d_B$	0	mm
Plafond	$d_C$	800	mm

## Distance par rapport aux matériaux combustibles pour un conduit de fumée isolé \*

Arrière	$d_R$	---	mm
Latéral	$d_s$	---	mm

## Distance par rapport aux matériaux combustibles avec plaque de suspension

Arrière	$d_R$	---	mm
Latéral	$d_s$	---	mm

## Distance par rapport aux matériaux combustibles pour un conduit de fumée isolé une plaque de suspension \*

Arrière	$d_R$	---	mm
Latéral	$d_s$	---	mm

## Distance par rapport aux matériaux non combustibles

Arrière	$d_{Rnon}$	80	mm
Latéral	$d_{Snon}$	150	mm
Latéral – niche	$d_{s2non}$	80	mm
Latéral – emplacement 45°	$d_{s3non}$	---	mm

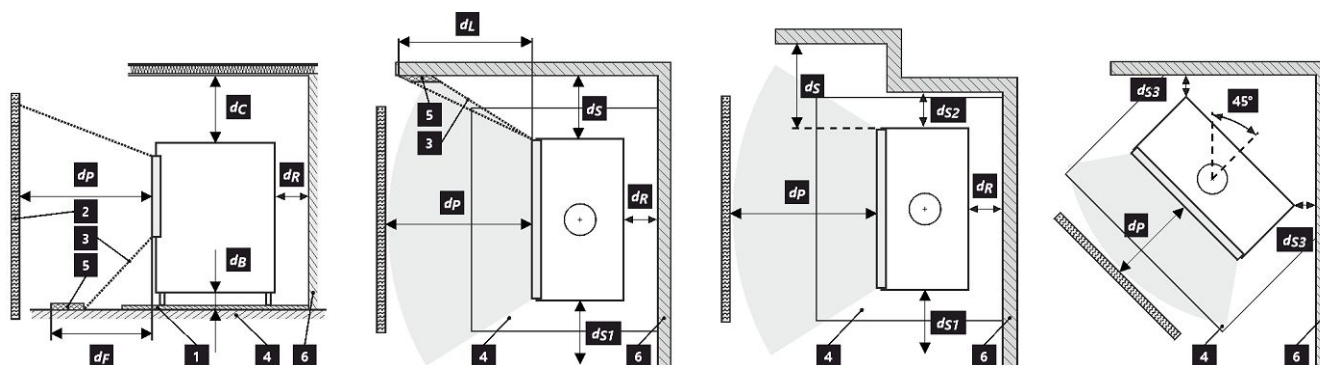

1 sol | 2 objet | 3 zone de rayonnement | 4 plaque de protection de sol | 5 zone critique (en raison du rayonnement) | 6 mur combustible

Lors de l'installation et de l'utilisation du produit, toutes les réglementations locales doivent être respectées, y compris celles relatives aux normes nationales et européennes.

Le produit installé sur un sol composé de matériaux combustibles doit être équipé d'une plaque de protection de sol en matériau non combustible dépassant d'au moins 400 mm à l'avant et 100 mm dans les autres directions par rapport à la surface de base du produit. Le produit doit être installé sur des sols présentant une capacité de charge suffisante.

\* La distance suppose l'utilisation d'un conduit de fumée isolé avec une épaisseur d'isolation minimale de 25 mm jusqu'au produit.

**Distance par rapport aux matériaux combustibles (non combustibles) – Raccordement arrière du conduit de fumée**

Arrière	$d_R$	200	mm
Latéral	$d_S$	250	mm

**Raccordement arrière du conduit de fumée**

**Passage du conduit de fumée à travers un mur en matériau combustible**

1. Mur
2. Conduit de fumée
3. Plaque de recouvrement (incombustibles, non métallique)
4. Rosage
5. Tuyau de protection
6. Remplissage isolant (incombustible, par exemple la fibre de verre)
7. Remplissage isolant (incombustible, par exemple l'argile des poêliers)

**Distance par rapport aux matériaux combustibles (non combustibles) – Raccordement arrière du conduit de fumée (isolé)**

Arrière	$d_R$	---	mm
Latéral	$d_S$	---	mm

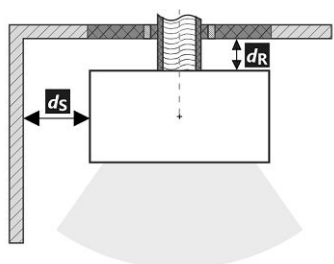
**Raccordement arrière du conduit de fumée (isolé)**

**Passage du conduit de fumée à travers un mur en matériau combustible**

1. Mur
2. Conduit de fumée isolé
3. Plaque de recouvrement (incombustibles, non métallique)
4. Rosage
5. Tuyau de protection
6. Remplissage isolant (incombustible, par exemple la fibre de verre)
7. Remplissage isolant (incombustible, par exemple l'argile des poêliers)

**Proprietà dichiarate del prodotto**

Specificazioni tecniche armonizzate			
✓ EN 16510-1 ed.2:2023   EN 16510-2-1:2022 ✓ Ecodesign ✓ DIN+ ✓ BlmSchV2 ✓ 15a B-VG 2015			
Classificazione del prodotto	Type BE		
		Potenza termica nominale (nom)	Potenza termica parziale (part)
Efficienza energetica	$\eta_{nom}   \eta_{part}$	81	---
Efficienza energetica stagionale del riscaldamento d'ambiente	$\eta_{s,nom}   \eta_{s,part}$	71	---
Indice di efficienza prodotto	EEI	107	
Etichetta energetica		A+	
Combustibile		Legna	
Combustibile – lunghezza		200-330	
Consumo medio di combustibile		1,69	---
Dose ammessa di combustibile		2,3	
Intervallo di aggiunta di combustibile		1 ora	
Quantità di aria di combustione		21,4	
Potenza termica nominale	$P_{nom}   P_{part}$	5,8	---
Potenza ter. nom. dello scambiatore di acqua calda	$P_{W,nom}   P_{W,part}$	---	---
Ppressione massima di funzionamento dell'acqua	$P_W$	---	
Portata dei fumi di scarico secchi	$\Phi_{f,g,nom}   \Phi_{f,g,part}$	6,9	---
Temperatura d'uscita dei gas di scarico	$T_{s,nom}   T_{s,part}$	313	---
Tiro di esercizio	$P_{nom}   P_{part}$	12	---
Classe di temperatura del camino		T400	
Collegamento al camino collettivo		Sì	
Stoccaggio del combustibile nell'area della stufa a legna		Sì	
Riscaldamento massimo della legna nella stufa a legna		20	
Polvere O <sub>2</sub> = 13 %	$PM_{nom}   PM_{part}$	26	---
CO <sub>2</sub>		10,24	---
Emissioni (CO nei gas comburenti all' O <sub>2</sub> = 13 %)	$CO_{nom}   CO_{part}$	0,0689 862	---
OGC O <sub>2</sub> = 13 %	$OGC_{nom}   OGC_{part}$	50	---
NOx O <sub>2</sub> = 13 %	$NO_{x,nom}   NO_{x,part}$	114	---
Controllo automatico della combustione		---	---
Consumo di energia elettrica in modo stand-by	$e_{l,SB}$	---	---
Consumo di energia elettrica	$e_{l,max}   e_{l,min}$	---	---
Perdita d'aria in piedi	$V_h$	---	---
Funzionamento intermittente   Funzionamento continuo	INT   CON	INT	

**Dati tecnici di base**

Dimensioni principali (Altezza   Larghezza   Profondità)	H   W   L	1058   900   380	mm
Dimensioni della camera di combustione (Altezza   Larghezza   Profondità)	H   W   L	357   344   276	mm
Dimensioni dello sportello del focolare (Alt.   Larg.   Prof.)	H   W   L	---   ---   ---	mm
Altezza dell'asse dell'uscita posteriore (laterale)		947	mm
Volume dello scambiatore di acqua calda		---	l
Diametro del condotto fumario		150	mm
Diametro del gola della canna fumaria	$d_{out}$	150	mm
Diametro dell'afflusso centralizzato di aria		125	mm
Lunghezza mass. (tubo) di alimentazione centrale dell'aria		5000	mm
Peso	m	131	kg
Capacità di carico	$m_{chim}$	200	kg

## Capacità termica (Potere calorifico)

dimensione minima del locale in cui è installato l'apparecchio

Isolamento della casa – molto buono (20 W/m <sup>3</sup> )	ad esempio, casa nuova e isolata / abitata in modo permanente	216	m <sup>3</sup>
Isolamento della casa – buono (22,5 W/m <sup>3</sup> )		192	m <sup>3</sup>
Isolamento della casa – medio (32 W/m <sup>3</sup> )		135	m <sup>3</sup>
Isolamento della casa – cattivo (45 W/m <sup>3</sup> )		96	m <sup>3</sup>
Isolamento della casa – molto male (50 W/m <sup>3</sup> )	ad esempio, una vecchia casa / un cottage / uno chalet non isolato	86	m <sup>3</sup>

## Distanza di materiali infiammabili

con canna fumaria non isolata (indicato sull'etichetta di produzione)

Nota

Posteriore	$d_R$	200	mm
Anteriore	$d_P$	1300	mm
Anteriore (rispetto al pavimento)	$d_F$	0	mm
Laterali	$d_S$	250	mm
Vetrata laterale	$d_{S1}$	---	mm
Laterali – nicchia	$d_{S2}$	200	mm
Laterali – posizione 45°	$d_{S3}$	---	mm
Radiazione laterale	$d_L$	0	mm
Dal pavimento	$d_B$	0	mm
Dal soffitto	$d_C$	800	mm

## Distanza di materiali infiammabili con canna fumaria isolata \*

Posteriore	$d_R$	---	mm
Laterali	$d_S$	---	mm

## Distanza di materiali infiammabili con una piastra di sospensione

Posteriore	$d_R$	---	mm
Laterali	$d_S$	---	mm

## Distanza di materiali infiammabili con canna fumaria isolata una piastra di sospensione \*

Posteriore	$d_R$	---	mm
Laterali	$d_S$	---	mm

## Distanza di materiali non infiammabili

Posteriore	$d_{Rnon}$	80	mm
Laterali	$d_{Snon}$	150	mm
Laterali – nicchia	$d_{S2non}$	80	mm
Laterali – posizione 45°	$d_{S3non}$	---	mm

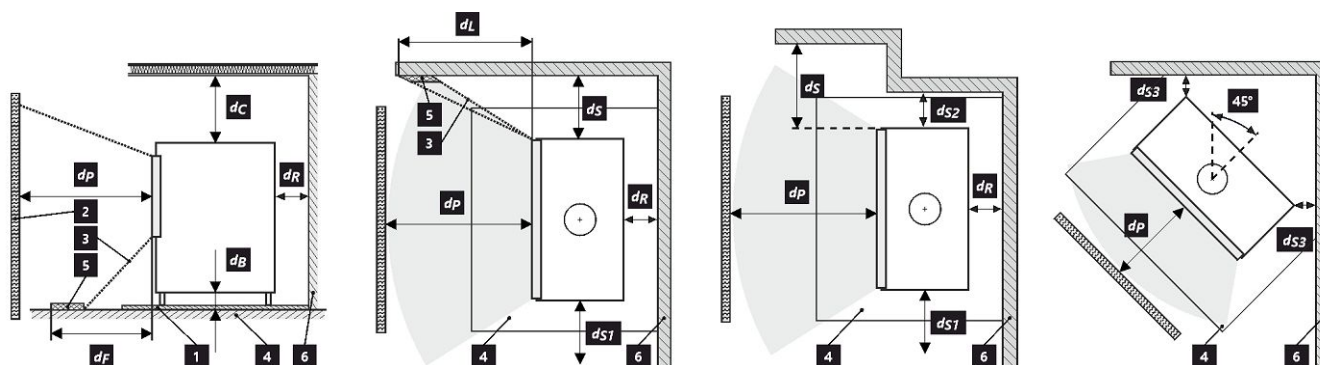

1 pavimento | 2 oggetto | 3 area di irraggiamento | 4 piastra protettiva del pavimento | 5 area critica (a causa dell'irraggiamento) | 6 parete combustibili

Durante il montaggio e l'uso del prodotto, devono essere rispettate tutte le normative locali, incluse le norme nazionali ed europee.

Il prodotto installato su un pavimento realizzato con materiali combustibili deve essere dotato di una piastra di protezione del pavimento in materiale non combustibile che sporga di almeno 400 mm in avanti e di 100 mm nelle altre direzioni rispetto alla superficie di appoggio del prodotto. Il prodotto deve essere installato su pavimenti con una portata sufficiente.

\* La distanza presuppone l'utilizzo di una canna fumaria isolata con uno spessore minimo di isolamento di 25 mm fino al prodotto.

**Distanza di materiali infiammabili (non infiammabili) – collegamento alla canna fumaria posteriore**

Posteriore	$d_R$	200	mm
Laterali	$d_S$	250	mm

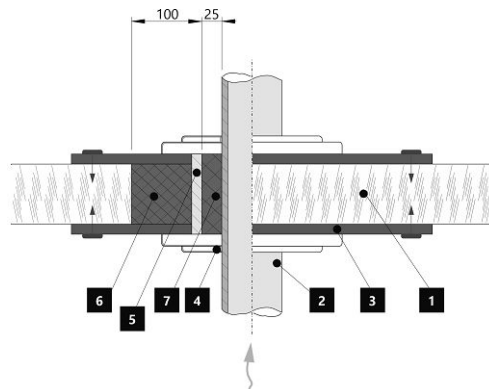
**Passaggio della canna fumaria attraverso una parete in materiale combustibile**

1. Muro
2. Canna fumaria
3. Piastra di copertura (non infiammabile, non metallica)
4. Rosetta
5. Tubo di protezione
6. Riempimento isolante (non infiammabile, ad es. Fibra di vetro)
7. Riempimento isolante (non infiammabile, ad esempio argilla per stufe)

**Distanza di materiali infiammabili (non infiammabili) – collegamento alla canna fumaria posteriore (isolato)**

Posteriore	$d_R$	---	mm
Laterali	$d_S$	---	mm

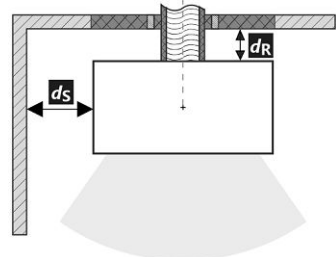
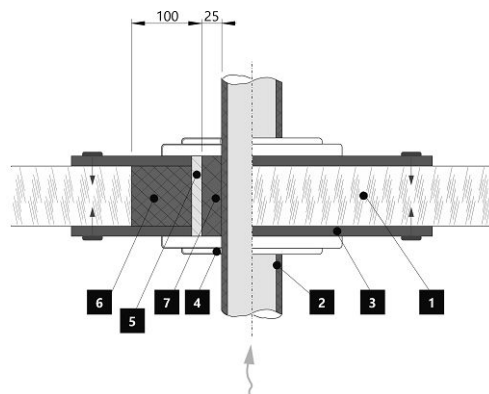
**Raccordo della canna fumaria posteriore (isolato)**

**Passaggio della canna fumaria attraverso una parete in materiale combustibile**

1. Muro
2. Canna fumaria isolata
3. Piastra di copertura (non infiammabile, non metallica)
4. Rosetta
5. Tubo di protezione
6. Riempimento isolante (non infiammabile, ad es. Fibra di vetro)
7. Riempimento isolante (non infiammabile, ad esempio argilla per stufe)

**Deklaracija lastnosti**

 Harmonizirana tehnična specifikacija ✓ EN 16510-1 ed.2:2023 | EN 16510-2-1:2022 ✓ Ecodesign ✓ DIN+ ✓ BlmSchV2 ✓ 15a B-VG 2015

Klasifikacija izdelka	Type BE		
		Nazivna toplotna moč (nom)	Toplotna moč pri delni obremenitvi (part)
Energetska učinkovitost	$\eta_{nom}   \eta_{part}$	81	---
Sezonska energetska učinkovitost pri ogrevanju prostorov	$\eta_{s,nom}   \eta_{s,part}$	71	---
Indeks energetske učinkovitosti	EEI	107	
Energijska nalepka		A+	
Gorivo		Drva	
Priporočljiva dolžina goriva		200-330	
Povprečna poraba lesa		1,69	---
Dovoljena količina lesa		2,3	
Interval dobave goriva za nazivno moč		1 ura	
Zahtevan zrak za izgorevanje		21,4	
Nazivna toplotna moč	$P_{nom}   P_{part}$	5,8	---
Izhod toplovodnega izmenjevalnika	$P_{W,nom}   P_{W,part}$	---	---
Maks. delovni tlak	$p_W$	---	
Masni pretok suhih dimnih plinov	$\Phi_{f,g,nom}   \Phi_{f,g,part}$	6,9	---
Temperatura izhodnih dimnih plinov	$T_{s,nom}   T_{s,part}$	313	---
Vlek dimnika	$p_{nom}   p_{part}$	12	---
Temperaturni razred kamina		T400	
Priključek na skupni dimnik		Da	
Skladiščenje goriva v območju peči		Da	
Maksimalno segrevanje lesa v območju peči na drva		20	
Prah O <sub>2</sub> = 13 %	$PM_{nom}   PM_{part}$	26	---
CO <sub>2</sub>		10,24	---
Emisije izgorevalnih plinov (CO v dimne pline pri O <sub>2</sub> = 13 %)	$CO_{nom}   CO_{part}$	0,0689 862	---
OGC O <sub>2</sub> = 13 %	$OGC_{nom}   OGC_{part}$	50	---
NOx O <sub>2</sub> = 13 %	$NO_{x,nom}   NO_{x,part}$	114	---
Avtomatska regulacija gorenja		---	---
Poraba električne energije v stanju pripravljenosti	$e_{l,SB}$	---	
Poraba električne energije	$e_{l,max}   e_{l,min}$	---	---
Stalna izguba zraka	$V_h$	---	
Prekinjeno delovanje   Nепrekinjeno delovanje	INT   CON	INT	

**Osnovni tehnični podatki**

Dimenzije (Višina   Širina   Globina)	H   W   L	1058   900   380	mm
Dimenzije zgorevalne komore (Višina   Širina   Globina)	H   W   L	357   344   276	mm
Dimenzije vrat peči (Višina   Širina   Globina)	H   W   L	---   ---   ---	mm
Višina osi zadnjega (stranskega) izpusta		947	mm
Prostornina toplotnega izmenjevalnika		---	l
Premer priključka dimne cevi		150	mm
Premer dimne cevi	$d_{out}$	150	mm
Zunanji dovod zraka (ZDZ)		125	mm
Največja dolžina (cevi) zunanje dovod zraka		5000	mm
Teža	m	131	kg
Nosilnost	$m_{chim}$	200	kg

## Moč ogrevanja (Kurilna vrednost)

najmanjša velikost prostora primernega za vgradnjo naprave

Izolacija hiše – zelo dobro (20 W/m <sup>3</sup> )	npr. nova, izolirana hiša / stalno naseljena	216	m <sup>3</sup>
Izolacija hiše – dobro (22,5 W/m <sup>3</sup> )		192	m <sup>3</sup>
Izolacija hiše – srednja (32 W/m <sup>3</sup> )		135	m <sup>3</sup>
Izolacija hiše – slabo (45 W/m <sup>3</sup> )		96	m <sup>3</sup>
Izolacija hiše – zelo slabo (50 W/m <sup>3</sup> )	npr. stara, neizolirana hiša / koča / brunarica	86	m <sup>3</sup>

## Varna razdalja od vnetljivega materiala

z neizolirano dimovodno cevjo (navedeno na nalepki izdelka)

Opomba

Zadaj	$d_R$	200	mm
Spredaj	$d_P$	1300	mm
Spredaj do tal	$d_F$	0	mm
Stran	$d_S$	250	mm
Stran s steklom	$d_{S1}$	---	mm
Stran – niša	$d_{S2}$	200	mm
Stran – postavitvev pod kotom 45°	$d_{S3}$	---	mm
Stransko sevanje	$d_L$	0	mm
Od tal	$d_B$	0	mm
Od stropa	$d_C$	800	mm

## Varna razdalja od vnetljivega materiala z izolirano dimovodno cevjo \*

Zadaj	$d_R$	---	mm
Stran	$d_S$	---	mm

## Varna razdalja od vnetljivega materiala s pokrovno ploščo (pokrovom)

Zadaj	$d_R$	---	mm
Stran	$d_S$	---	mm

## Varna razdalja od vnetljivega materiala z izolirano dimovodno cevjo s pokrovno ploščo (pokrovom) \*

Zadaj	$d_R$	---	mm
Stran	$d_S$	---	mm

## Varna razdalja od negorljivega materiala

Zadaj	$d_{Rnon}$	80	mm
Stran	$d_{Snon}$	150	mm
Stran – niša	$d_{S2non}$	80	mm
Stran – postavitvev pod kotom 45°	$d_{S3non}$	---	mm

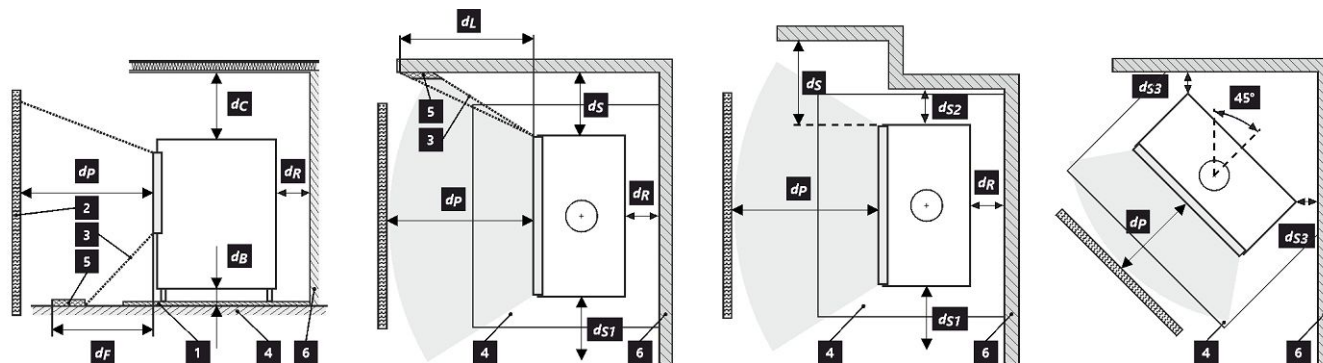

1 podlaga | 2 predmet | 3 območje sevanja | 4 zaščitna talna plošča | 5 kritično območje (zaradi sevanja) | 6 vnetljivih stena

Pri montaži in delovanju izdelka morajo biti upoštevani vsi lokalni predpisi, vključno predpisi, ki se nanašajo na lokalne in Evropske standarde.

Izdelek, nameščen na tleh iz vnetljivih materialov, mora biti opremljen z zaščitno blazinico iz nevnetljivega materiala, ki sega čez tloris izdelka vsaj 400 mm v sprednjo smer in 100 mm v druge smeri. Izdelek mora biti nameščen na tleh z ustrezno nosilnostjo.

\* Razdalja predpostavlja uporabo izolirane dimovodne cevi z najmanjšo debelino izolacije 25 mm do izdelka.

**Varna razdalja od vnetljivega (negorljivega) materiala – priključek iz hrbtnega dimniškega izpusta**

Zadaj	$d_R$	200	mm
Stran	$d_S$	250	mm

Dimniški izpust iz hrbtne strani

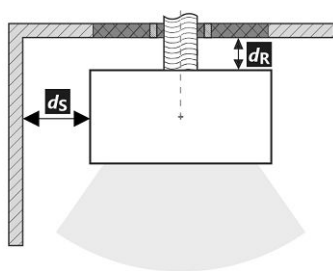

Prehod dimnovodne cevi skozi steno iz gorljivega materiala

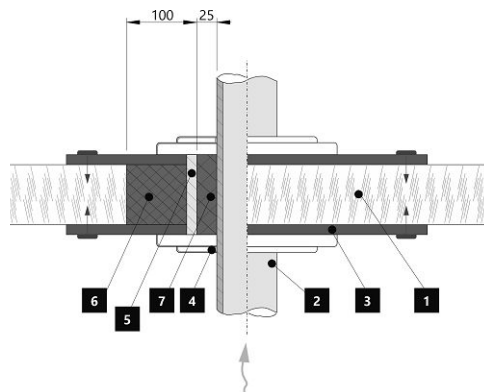

1. Stena
2. Dimne cevi
3. Pokrivna plošča (negorljiva, nekovinska)
4. Rozeta
5. Zaščitna cev
6. Izolacijsko polnilo (nevnetljivo, npr. steklena vlakna)
7. Izolacijsko polnilo (nevnetljivo, npr. glinena peči)

**Varna razdalja od vnetljivega (negorljivega) materiala – priključek iz hrbtne dimniškega izpusta (izoliran)**

Zadaj	$d_R$	---	mm
Stran	$d_S$	---	mm

Dimniški izpust iz zadnje strani (izoliran)

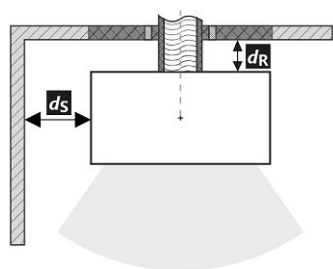

Prehod dimnovodne cevi skozi steno iz gorljivega materiala

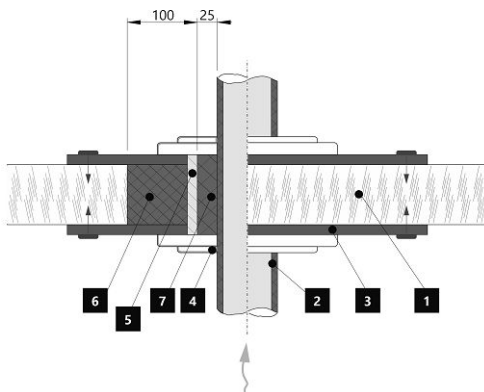

1. Stena
2. Izolirana dimnovodna cev
3. Pokrivna plošča (negorljiva, nekovinska)
4. Rozeta
5. Zaščitna cev
6. Izolacijsko polnilo (nevnetljivo, npr. steklena vlakna)
7. Izolacijsko polnilo (nevnetljivo, npr. glinena peči)

**Ilmoitetut ominaisuudet**

Yhdenmukaistetut tekniset tiedot ✓ EN 16510-1 ed.2:2023 | EN 16510-2-1:2022 ✓ Ecodesign ✓ DIN+ ✓ BImSchV2 ✓ 15a B-VG 2015

Laitteen luokittelu	Type BE			
		Nimellinen lämmöntuotto (nom)	Lämmöntuotto osakuormalla (part)	
Energiatehokkuus	$\eta_{nom}   \eta_{part}$	81	---	%
Tilojen kausilämmityksen energiatehokkuus at nominal heat output	$\eta_{snom}   \eta_{spart}$	71	---	%
Energiatehokkuusindeksi	EEI	107		
Energiamerkintä		A+		
Polttoaine		Puuhalot		
Polttopuun pituus		200-330		mm
Keskimääräinen polttoaineenkulutus		1,69	---	kg/h
Sallittu puumäärä		2,3		kg/h
Puun lisäysväli		1 tunti		
Palamisilman määrä		21,4		m <sup>3</sup> /h
Nimellinen lämmöntuotto	$P_{nom}   P_{part}$	5,8	---	kW
Vesilämmönsiirtimen teho	$P_{Wnom}   P_{Wpart}$	---	---	kW
Veden maksimi käyttöpaine	$P_W$	---		bar
Kuivan savukaasun massavirta	$\Phi_{f,g nom}   \Phi_{f,g part}$	6,9	---	g/s
Savukaasujen ulostulolämpötila	$T_{snom}   T_{spart}$	313	---	°C
Savuputken veto	$P_{nom}   P_{part}$	12	---	Pa
Hormin lämpötilaluokka		T400		
Liitäntä yhteiseen hormiin		Kyllä		
Polttoaineen varastointialue Puun maksimaalinen lämpeneminen varastointialueella		Kyllä 20		°C
Pöly O <sub>2</sub> = 13 %	$PM_{nom}   PM_{part}$	26	---	mg/Nm <sup>3</sup>
CO <sub>2</sub>		10,24	---	%
Pölykaasupäästöt (CO savukaasuissa O <sub>2</sub> = 13 %)	$CO_{nom}   CO_{part}$	0,0689 862	---	% mg/Nm <sup>3</sup>
OGC O <sub>2</sub> = 13 %	$OGC_{nom}   OGC_{part}$	50	---	mg/Nm <sup>3</sup>
NOx O <sub>2</sub> = 13 %	$NO_{xnom}   NO_{xpart}$	114	---	mg/Nm <sup>3</sup>
Automaattinen palamisen säätöyksikkö		---	---	
Virrankulutus valmiustilassa	$e_{SB}$	---		kW
Virrankulutus	$e_{lmax}   e_{lmin}$	---	---	kW
Seisovan ilman häviö	$V_h$	---		m <sup>3</sup> /h
Ajoittainen käyttö   Jatkuva käyttö	INT   CON	INT		

**Tekniset perustiedot**

Tärkeimmät mitat (Korkeus   Leveys   Pituus)	H   W   L	1058   900   380	mm
Palotilan mitat (Korkeus   Leveys   Pituus)	H   W   L	357   344   276	mm
Takan luukun mitat (Korkeus   Leveys   Pituus)	H   W   L	---   ---   ---	mm
Takimmaisena (sivu-)ulostuloaukon korkeus		947	mm
Vesilämmönsiirtimen tilavuus		---	l
Hormin halkaisija		150	mm
Savukanavan liitännän halkaisija	$d_{out}$	150	mm
Ulkoilmaliitännän halkaisija		125	mm
Ulkoisen ilmanoton enimmäispituus (putki)		5000	mm
Paino	m	131	kg
Kantavuus	$m_{chim}$	200	kg

## Lämpökapasiteetti

huoneen vähimmäiskoko, johon laite asennetaan

Talon lämmöneristys – erinomainen (20 W/m <sup>3</sup> )	esim. uusi lämmöneristetty talo / pysyvästi asuttu	216	m <sup>3</sup>
Talon lämmöneristys – hyvä (22,5 W/m <sup>3</sup> )		192	m <sup>3</sup>
Talon lämmöneristys – tyydyttävä (32 W/m <sup>3</sup> )		135	m <sup>3</sup>
Talon lämmöneristys – vähäinen (45 W/m <sup>3</sup> )		96	m <sup>3</sup>
Talon lämmöneristys – erittäin huono (50 W/m <sup>3</sup> )	esim. vanha, lämmöneristämätön talo / mökki / alppimaja	86	m <sup>3</sup>

## Suojaetäisyydet syttyviin materiaaleihin

eristämättömällä savuputkella (ilmoitettu tuotteen etiketissä)

Huomautus

Takaosa	$d_R$	200	mm
Etuosa	$d_P$	1300	mm
Etuosasta lattiaan	$d_F$	0	mm
Sivu	$d_S$	250	mm
Sivu, jossa lasia	$d_{S1}$	---	mm
Sivu – syvennys	$d_{S2}$	200	mm
Sivu – sijainti 45°	$d_{S3}$	---	mm
Sivusäteily	$d_L$	0	mm
Lattiasta	$d_B$	0	mm
Katosta	$d_C$	800	mm

## Suojaetäisyydet syttyviin materiaaleihin eristetyn savuputken yhteydessä \*

Takaosa	$d_R$	---	mm
Sivu	$d_S$	---	mm

## Suojaetäisyydet syttyviin materiaaleihin yhteydessä ripustuslevyllä (suojaus)

Takaosa	$d_R$	---	mm
Sivu	$d_S$	---	mm

## Suojaetäisyydet syttyviin materiaaleihin eristetyn savuputken yhteydessä ripustuslevyllä (suojaus) \*

Takaosa	$d_R$	---	mm
Sivu	$d_S$	---	mm

## Suojaetäisyydet syttymättömiin materiaaleihin

Takaosa	$d_{Rnon}$	80	mm
Sivu	$d_{Snon}$	150	mm
Sivu – syvennys	$d_{S2non}$	80	mm
Sivu – sijainti 45°	$d_{S3non}$	---	mm

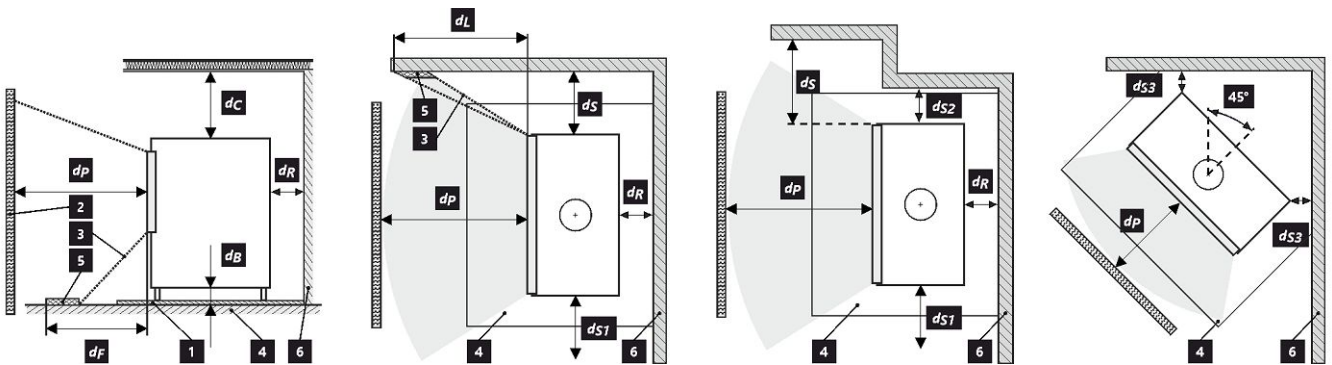

1 lattia | 2 esine | 3 säteilyn alue | 4 lattian suojalevy | 5 kriittinen alue (säteilyn vuoksi) | 6 syttyvistä seinä

Tuotteen asennuksessa ja käytössä on noudatettava kaikkia paikallisia määräyksiä, mukaan lukien kansallisiin ja eurooppalaisiin standardeihin liittyvät määräykset.

Syttyvistä materiaaleista valmistetulle lattialle asennettu tuote on varustettava syttymättömästä materiaalista valmistetulla suoja-alustalla, jonka on ulotuttava tuotteen jalanjaljen ulkopuolelle vähintään 400 mm eteenpäin ja 100 mm muihin suuntiin. Tuote on asennettava riittävän kantaville lattioille.

\* Etäisyys edellyttää eristettyä savuputkea, jonka eristeen paksuus on vähintään 25 mm tuotteeseen asti.

## Suojaetäisyydet syttyviin (syttymättömiin) materiaaleihin – hormiliitos takana

Takaosa	$d_R$	200	mm
Sivu	$d_S$	250	mm

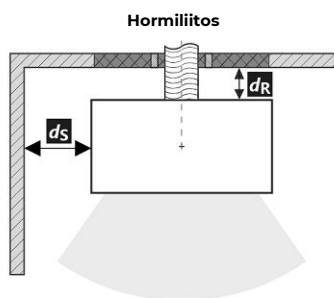

Savupiipun asennus palavasta materiaalista tehdyn seinän läpi

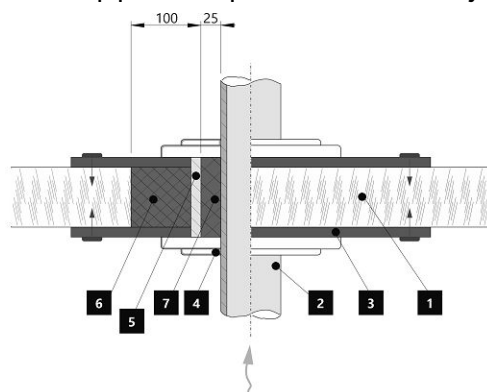

1. Seinä
2. Savuputki
3. Peitelevy (syttymätön, ei-metallinen)
4. Ruusuke
5. Protective tube
6. Eristetäyte (syttymätön, esim. lasikuitu)
7. Eristetäyte (syttymätön, esim. uunisavi)

## Suojaetäisyydet syttyviin (syttymättömiin) materiaaleihin – hormiliitos takana (eristetty)

Takaosa	$d_R$	---	mm
Sivu	$d_S$	---	mm

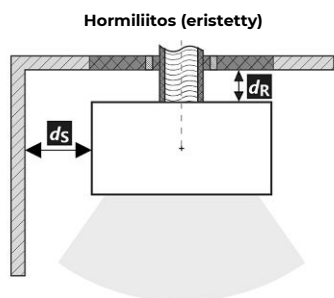

Savupiipun asennus palavasta materiaalista tehdyn seinän läpi

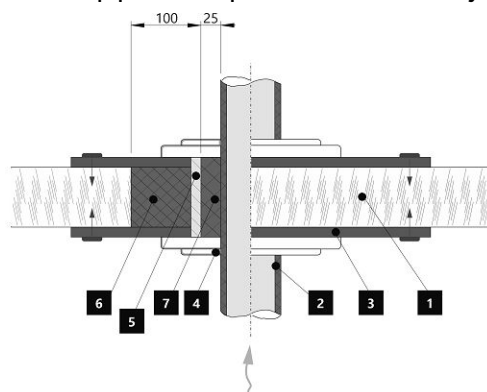

1. Seinä
2. Eristetty savuputki
3. Peitelevy (syttymätön, ei-metallinen)
4. Ruusuke
5. Protective tube
6. Eristetäyte (syttymätön, esim. lasikuitu)
7. Eristetäyte (syttymätön, esim. uunisavi)

**Deklareeritud omadused**

Harmoneeritud tehniline spetsifikatsioon ✓ EN 16510-1 ed.2:2023 | EN 16510-2-1:2022 ✓ Ecodesign ✓ DIN+ ✓ BImSchV2 ✓ 15a B-VG 2015

Seadme klassifikatsioon	Type BE		
	Nimivõimsuse juures (nom)	Osalise võimsuse juures (part)	
Energiaühik	$\eta_{nom}$   $\eta_{part}$	81	---
Kütmise sesoonne energiaühik	$\eta_{snom}$   $\eta_{spart}$	71	---
Energiaühikude indeks	EEI	107	
Energiamärgis		A+	
Küttematerjal		Puuhalud	
Küttematerjali pikkus		200-330 mm	
Keskmine küttematerjali tarve		1,69	---
Lubatud küttematerjali hulk		2,3 kg/h	
Küttematerjali lisamise intervall		1 tund	
Põlemisõhu hulk		21,4 m <sup>3</sup> /h	
Nimivõimsus	$P_{nom}$   $P_{part}$	5,8	---
Soojusvaheti võimsus	$P_{Wnom}$   $P_{Wpart}$	---	---
Maksimaalne veesurve	$P_W$	---	
Suitsugaaside kuivmass määr	$\Phi_{f,g nom}$   $\Phi_{f,g part}$	6,9	---
Suitsugaaside temperatuur lõõrist väljumisel	$T_{snom}$   $T_{spart}$	313	---
Suitsutoru tõmme	$P_{nom}$   $P_{part}$	12	---
Korstna temperatuuriklass		T400	
Ühendus üldkorstnaga		Jah	
Küttematerjali ladustamine puude säilitusalal		Jah	
Puidu maksimaalne soojenemine säilitusalal		20 °C	
Tolm O <sub>2</sub> = 13 %	$PM_{nom}$   $PM_{part}$	26	---
CO <sub>2</sub>		10,24	---
Põlemisgaaside emissioon suitsugaaside CO kui O <sub>2</sub> = 13 %)	$CO_{nom}$   $CO_{part}$	0,0689 862	---
OGC O <sub>2</sub> = 13 %	$OGC_{nom}$   $OGC_{part}$	50	---
NO <sub>x</sub> O <sub>2</sub> = 13 %	$NO_{xnom}$   $NO_{xpart}$	114	---
Automaatne põlemise reguleerimiseseade		---	---
Elektritarbimine ooterežiimis	$e_{SB}$	---	
Energiaühik	$e_{max}$   $e_{min}$	---	---
Seisva õhu kadu	$V_h$	---	
Vahelduv töö   Pidev töö	INT   CON	INT	

**Tehnilised põhiaandmed**

Põhimõõtmed (Kõrgus   Laius   Pikkus)	H   W   L	1058   900   380	mm
Põlemiskambri mõõdud (Kõrgus   Laius   Pikkus)	H   W   L	357   344   276	mm
Kolde ukse mõõdud (Kõrgus   Laius   Pikkus)	H   W   L	---   ---   ---	mm
Tagumise (külgmise) väljalaskeava telje kõrgus		947	mm
Sooja vee soojusvaheti maht		---	l
Suitsutoru diameeter		150	mm
Suitsutoru ava diameeter	$d_{out}$	150	mm
Välisõhu ühenduse diameeter		125	mm
Õhu sissevõtutoru maksimaalne pikkus		5000	mm
Kaal	m	131	kg
Kandevõime	$m_{chim}$	200	kg

## Soojusmahutavus

seadme paigaldamiseks sobiva ruumi vähim suurus

Hoone soojustus – väga hea (20 W/m <sup>3</sup> )	nt uus soojustatud hoone / hoone, milles elatakse aasta ringi	216	m <sup>3</sup>
Hoone soojustus – hea (22,5 W/m <sup>3</sup> )		192	m <sup>3</sup>
Hoone soojustus – keskmine (32 W/m <sup>3</sup> )		135	m <sup>3</sup>
Hoone soojustus – halb (45 W/m <sup>3</sup> )		96	m <sup>3</sup>
Hoone soojustus – väga halb (50 W/m <sup>3</sup> )	nt vana soojustamata hoone / suvila	86	m <sup>3</sup>

## Kaugus süttivatest materjalidest

isolatsioonita suitsutoruga (kirjeldatud toote etiketil)

Note

Tagaosa	$d_R$	200	mm
Esiosa	$d_P$	1300	mm
Esiosast pörandani	$d_F$	0	mm
Külg	$d_S$	250	mm
Klaasiga külg	$d_{S1}$	---	mm
Külg – nišš	$d_{S2}$	200	mm
Külg – asend 45°	$d_{S3}$	---	mm
Kiirgus külje suunas	$d_L$	0	mm
Pörandast	$d_B$	0	mm
Laest	$d_C$	800	mm

## Kaugus süttivatest materjalidest isolatsiooniga suitsutoruga \*

Tagaosa	$d_R$	---	mm
Külg	$d_S$	---	mm

## Kaugus süttivatest materjalidest rippuva plaadiga (kattega)

Tagaosa	$d_R$	---	mm
Külg	$d_S$	---	mm

## Kaugus süttivatest materjalidest isolatsiooniga suitsutoruga rippuva plaadiga (kattega) \*

Tagaosa	$d_R$	---	mm
Külg	$d_S$	---	mm

## Kaugus mittesüttivatest materjalidest

Tagaosa	$d_{Rnon}$	80	mm
Külg	$d_{Snon}$	150	mm
Külg – nišš	$d_{S2non}$	80	mm
Külg – asend 45°	$d_{S3non}$	---	mm

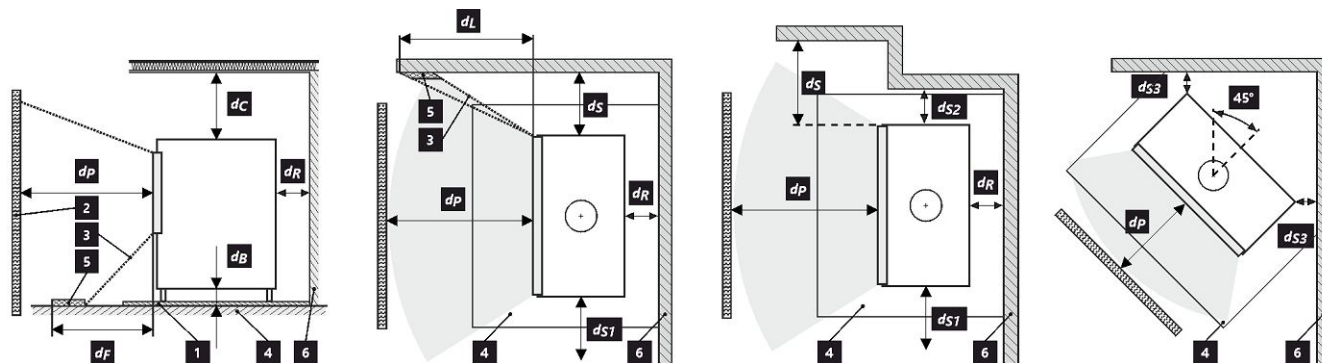

1 pörand | 2 objekt | 3 kiirgusala | 4 pörandi kaitseplaat | 5 kriitiline ala (kiirguse tõttu) | 6 tuleohtlik sein

Toote paigaldamise ja kasutamise ajal tuleb järgida kõiki kohalikke määrusi, kaasa arvatud siseriiklikest ja Euroopa standarditest tulenevad määrused.

Tuleohtlikust materjalist pörandale paigaldatud toode peab olema varustatud mittesüttivast materjalist kaitsepadjaga, mis ulatub toote jalajäljest vähemalt 400 mm ettepoole ja 100 mm teistes suundades väljapoole. Toode tuleb paigaldada piisava kandevõimega pörandatele.

\* Kaugus eeldab isolatsiooniga suitsutoru kasutamist, millel on tooteni ulatuv vähemalt 25 mm paksune isolatsioon.

**Kaugus süttivatest (mittesüttivatest) materjalidest – tagumine lõõr**

Tagaosa	$d_R$	200	mm
Külg	$d_S$	250	mm

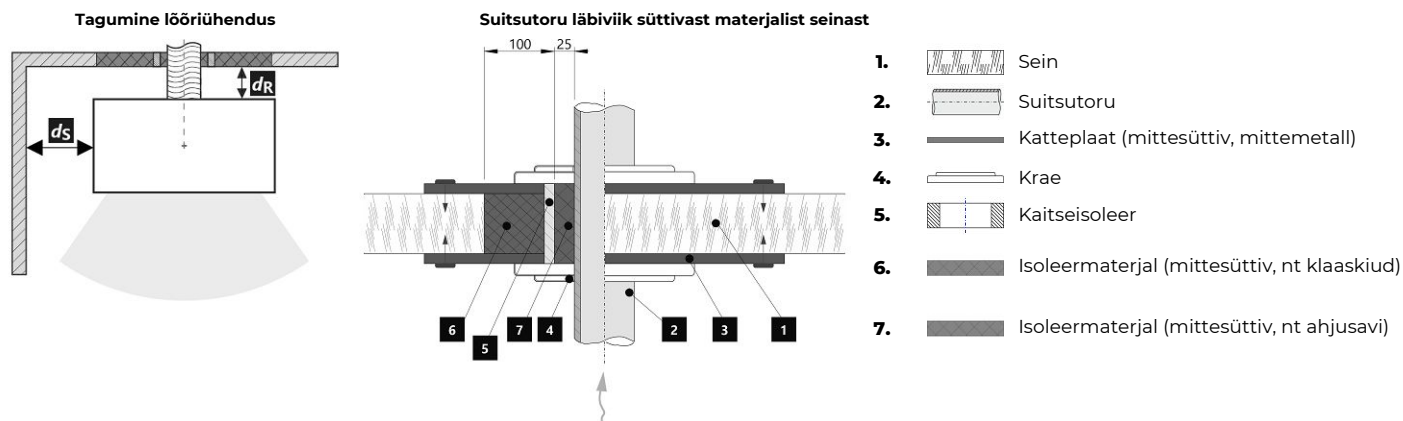
**Kaugus süttivatest (mittesüttivatest) materjalidest – tagumine lõõr (isolatsiooniga)**

Tagaosa	$d_R$	---	mm
Külg	$d_S$	---	mm

