

Rozměry v mm; Maße in mm

# CARA C 03

295kg

Litínový odvod kouře  
Cast iron spigot  
Der gusseiserne Rauchabgang

Výstup M10  
Reservoir M10  
Tauchhülse M10

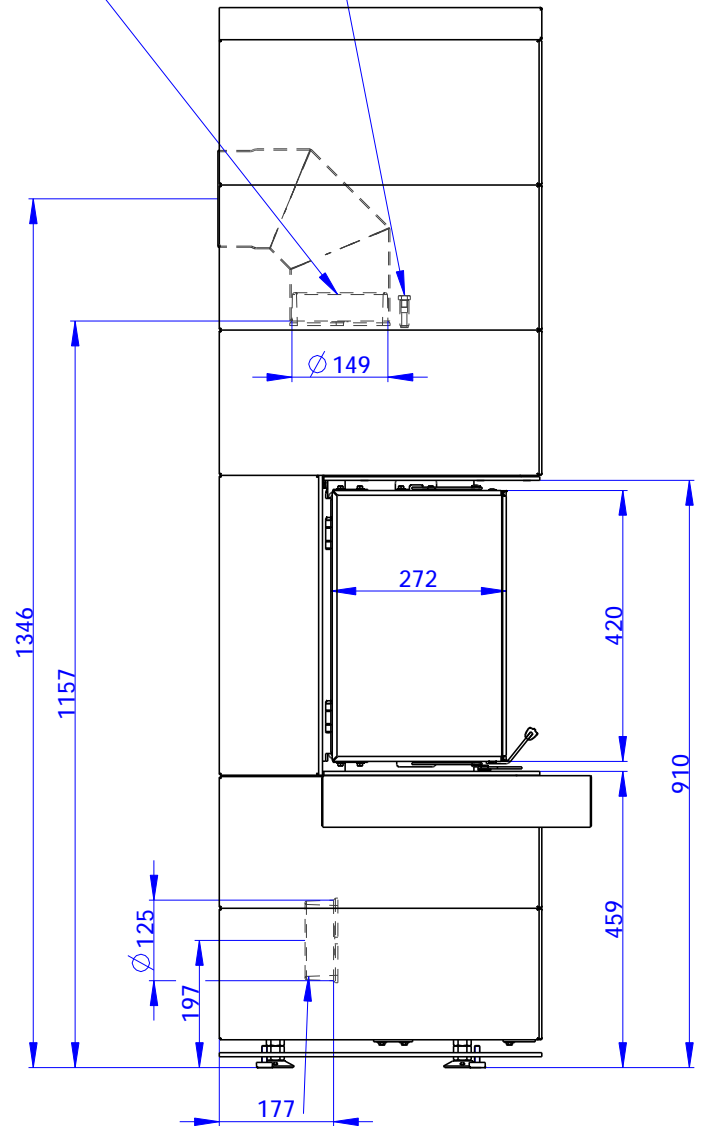
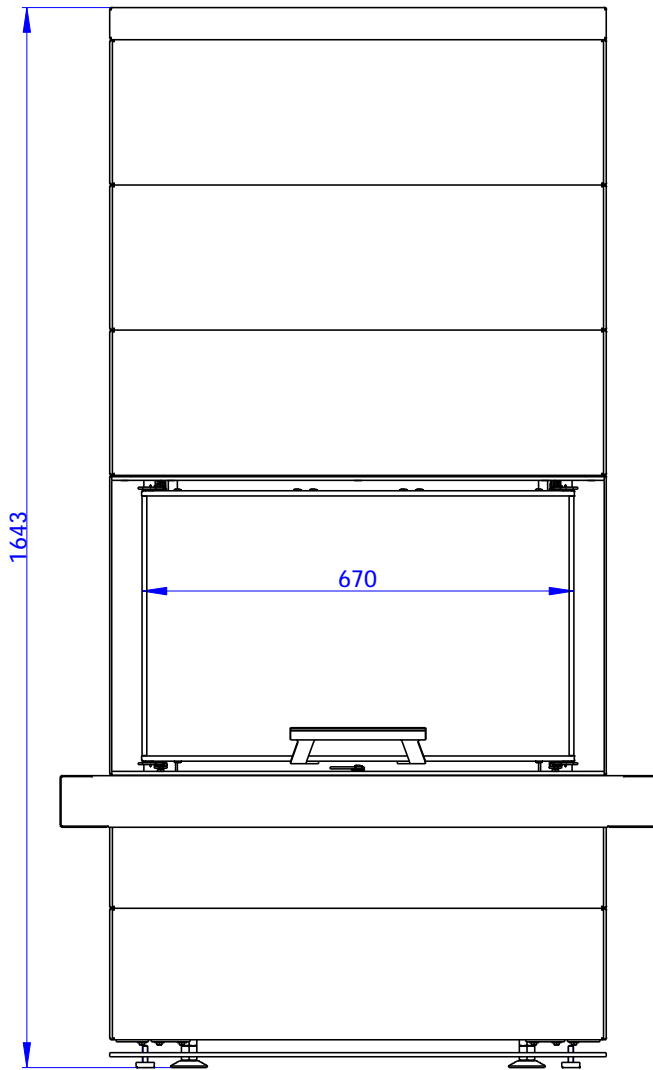

Centrální privod vzduchu  
Central air inlet  
Zentralluftzufuhr

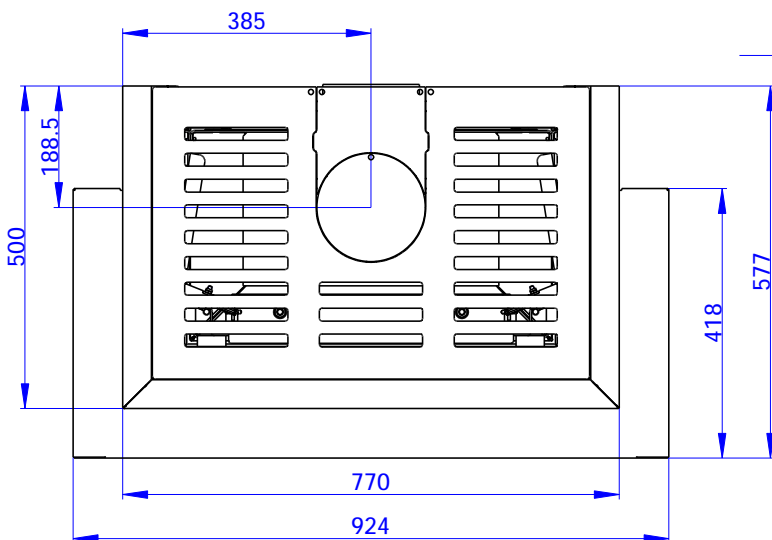

Primární a sekundární vzduch  
Primärluft und Sekundärluft  
Primary and secondary air

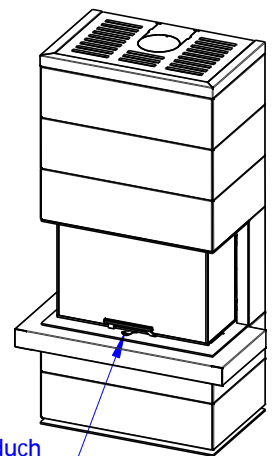

Rozměry v mm  
Maße in mm  
Dimensions in mm

# CARA C 03 + H2 AIRBOX 01

